

**Contents**

	<b>Page</b>
Installation .....	29
KP thermostat with air sensor .....	29
Setting .....	30
Thermostats with automatic reset .....	30
Thermostats with maximum reset .....	30
Thermostats with minimum reset .....	30
Setting example .....	31
Test of contact function .....	31
KP 98 dual thermostat .....	31
The correct thermostat for your refrigeration system .....	32
Vapour charge .....	32
Absorption charge .....	32
Low voltage .....	32
Placing of surplus capillary tube .....	33
Thermostats with vapour charge .....	33



**Installation**

If the risk of water droplets or water spray is present, fit a top plate. The plate increases the grade of enclosure to IP 44 and is suitable for all KP thermostats. The top plate must be purchased separately (Code no.: for single unit, 060-109766; for dual unit, 060-109866).

To obtain IP 44, cover all holes in the backplate of the thermostat.

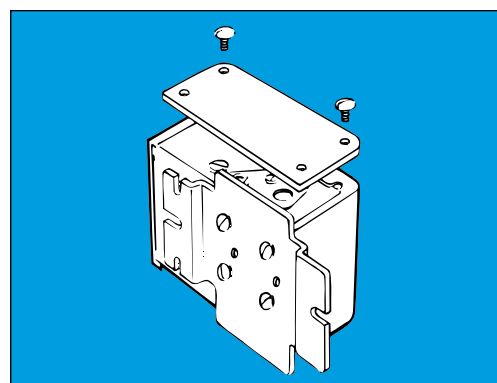

Aj0\_0001

If the unit is to be used in dirty conditions or where it might be exposed to heavy spray it should be fitted with a protective cap. The cap can be used together with either an angle bracket (060-105666) or a wall bracket (060-105566).

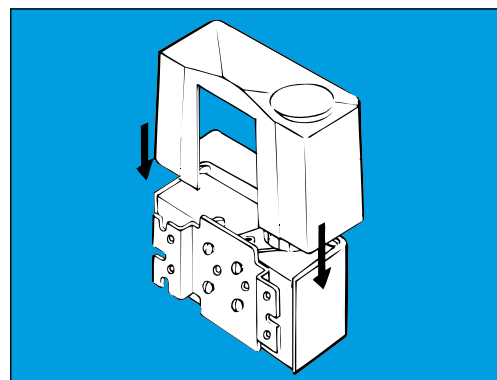

Aj0\_0002

If the unit risk being exposed to heavy water influence a better grade of enclosure can be achieved when mounting the product in a special IP 55 enclosure  
The IP 55 enclosure is available for both single unit (060-033066) and dual unit (060-035066).



Ak0\_0020

*KP thermostat with air sensor*

Remember that the differential is affected by air circulation around the sensor. Insufficient air circulation can increase the differential by 2-3°C.

Place the room thermostat so that air is able to flow freely around the sensor. At the same time, ensure that the sensor is not exposed to draughts from doors or radiation from the evaporator surface.

Never place the thermostat directly on a cold wall; this increases the differential. Instead, mount the unit on an insulating plate.

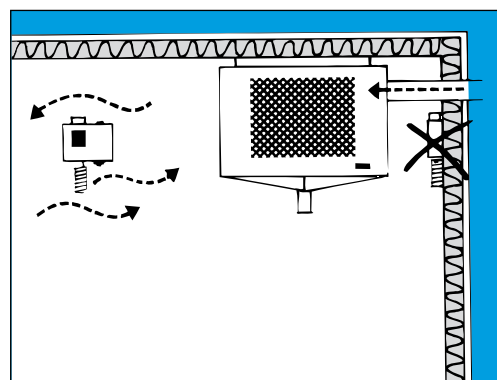

Aj0\_0003

**Fitters notes**
**Thermostats**

*KP thermostat with air sensor (cont.)*

When placing the sensor: Remember that air must be able to circulate freely around the sensor. With control from, for example, return air temperature, the sensor must not touch the evaporator.



Ah0\_0006

**KP thermostat with cylindrical sensor**

There are three ways of securing the sensor:

- 1) The pipe.
- 2) Between evaporator fins.
- 3) In a pocket.

When using a pocket: Always use heat-conductive compound (code no. 041E0110) to ensure good contact between sensor and medium.

**Setting**

*Thermostats with automatic reset*

Always set the highest temperature on the range scale. Then set the differential on the DIFF scale.

The temperature setting on the range scale then corresponds to the temperature at which a refrigeration compressor will be started on rising temperature. The compressor will stop when the temperature corresponds to the value set on the DIFF scale.

For pre-setting of vapour charged thermostats, the graph curves stated in the customer instruction sheet should be used.

If the compressor will not stop when it is set for low stop temperatures: Check to see whether the differential has been set at too high a value.

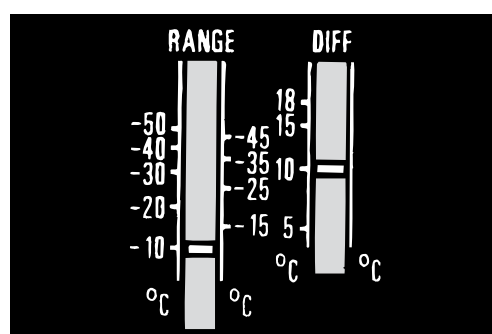

Aj0\_0004

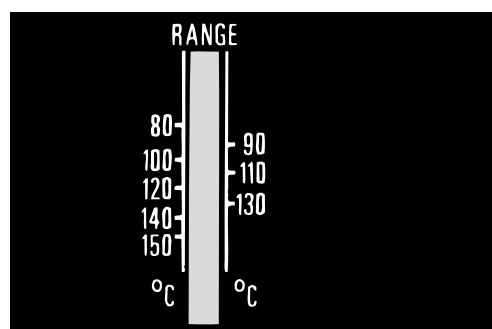

Aj0\_0005

*Thermostats with maximum reset*

Set the highest temperature = stop temperature on range scale.

The differential setting is fixed. When the temperature on the thermostat sensor corresponds to the differential setting, the system can be restarted by pressing the "Reset" button.

*Thermostats with minimum reset*

Set the lowest temperature = stop temperature on range scale.

The differential setting is fixed. When the temperature around the thermostat sensor has risen to the differential setting, the compressor can be restarted by pressing the "Reset" button.

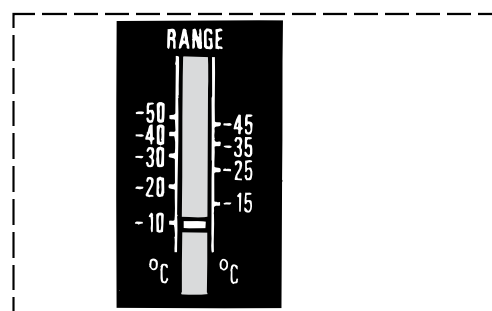

Aj0\_0006

**Setting example**

The temperature in a deep freeze room is to be controlled by a thermostat that closes a solenoid valve. The system is of the pump-down type and is stopped via a low-pressure control. Here, the pressure control must not be set to cut out at a pressure lower than necessary. At the same time, it must cut in at a pressure corresponding to the cut-in temperature of the thermostat.

*Example:*

Deep freeze room with	R404A
Room temperature:	-20°C
Thermostat cut out temperature:	-20°C
Thermostat cut in temperature:	-18°C
Pressure control cut out pressure:	0.9 bar (-32°C)
Pressure control cut in pressure:	2.2 bar (-18°C)

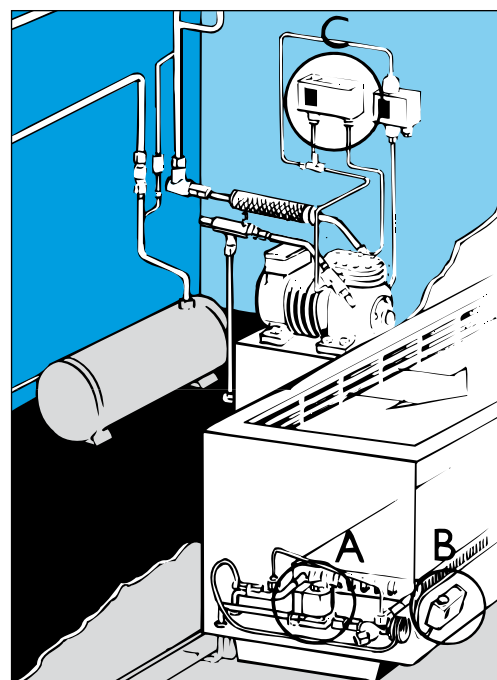

Aj0\_0007

Thermostats

**Test of contact function**

When the electrical leads are connected, the contact function can be tested manually. Depending on the sensor temperature and the thermostat setting, the test device must be pressed up or down. Any reset mechanism becomes inoperative during the test.

Use the test device at top left.

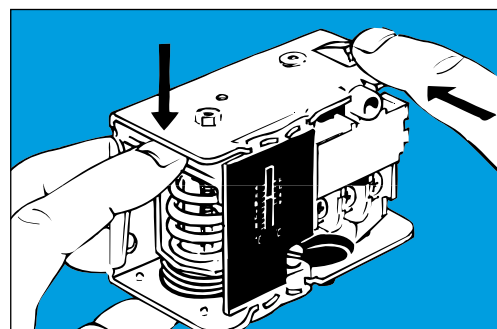

Aj0\_0009



**Warning!**

The contact function on a KP single thermostat must never be tested by activating the device on the righthand side. If this warning is ignored, the thermostat might go out of adjustment. In the worst case, function can be impaired.

*KP 98 dual thermostat*

Use the test device on the lefthand side to test function on rising oil temperature and the test device at bottom right to test function on rising pressure gas temperature.

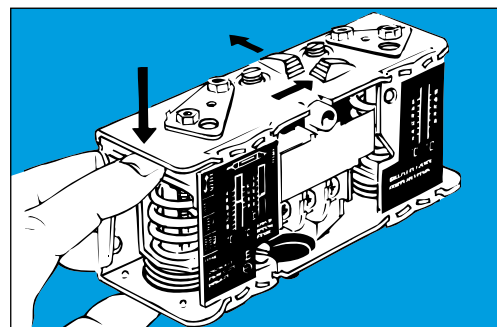

Aj0\_0010

**Fitters notes**
**Thermostats**
**The correct thermostat for your refrigeration system**





A thermostat must contain the correct charge, as described below.

*Vapour charge*

Low temperatures, coldest bellows, not enclosure-sensitive.  
 Thermostat with air coil: On gradual temperature rise and fall (less than 0.2K/min), e.g. in large, sluggish cold rooms containing many items, KP 62 with vapour charge is recommended.

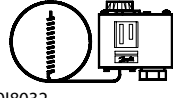
*Absorption charge*

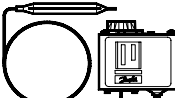
High temperatures, enclosure-sensitive. Bellows colder or warmer.  
 Thermostat with air coil: On fast changes in temperature (more than 0.2K/min), e.g. in smaller cold rooms where the produce turnover rate is high, KP 62 with absorption charge is recommended.

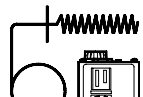
<b>Vapour charge</b>	 6018012	Straight capillary tube
	 6018032	Remote air coil
	 6018013	Air coil (integral with thermostat)
<b>Absorption charge</b>	 6018017	Double contact remote bulb
	 6018008	Cylindric remote bulb
	 6018013	Air coil (integral with thermostat)
	 6018018	Remote air coil (for duct mounting)

*Low voltage*

For systems where KP is activated occasionally (alarm) and for systems where KP is the signal source for PLC, etc. (low voltage): Use KP with gold contacts; these give good contact at low voltages.

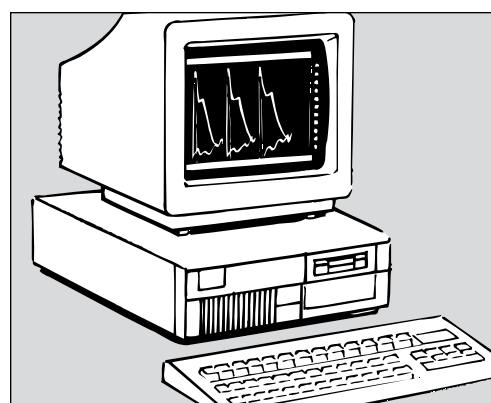

Aj0\_0012

**Placing of surplus capillary tube**

*Dual thermostat KP 98:*

Surplus capillary tube can fracture if vibration occurs and might lead to loss of thermostat charge. It is therefore very important that the following rules be observed:

- When mounting direct on compressor: Secure the capillary tube so that the compressor/thermostat installation vibrates as a whole. Surplus capillary tube must be coiled and bound.
- Other types of mounting: Coil surplus capillary tube into a loose loop. Secure the length of capillary tube between compressor and loop to the compressor. Secure the length of capillary tube between loop and thermostat to the base on which the thermostat is mounted.

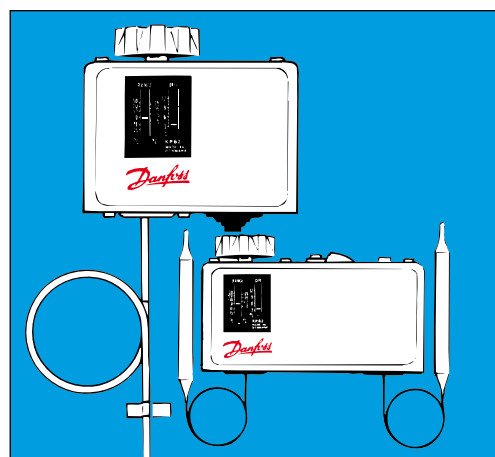

Aj0\_0017

**Thermostats with vapour charge**

Never locate a KP thermostat with vapour charge in a room where the temperature is or can be lower than that in the cold room.

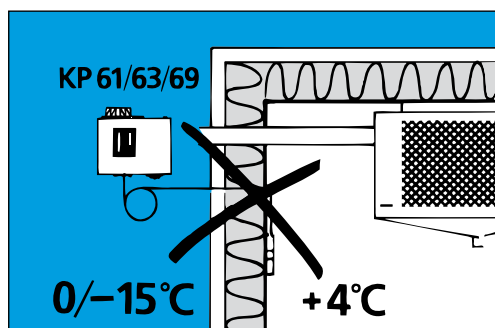

Aj0\_0014

Never allow the capillary tube from a KP thermostat to run alongside of a suction line in a wall entry.

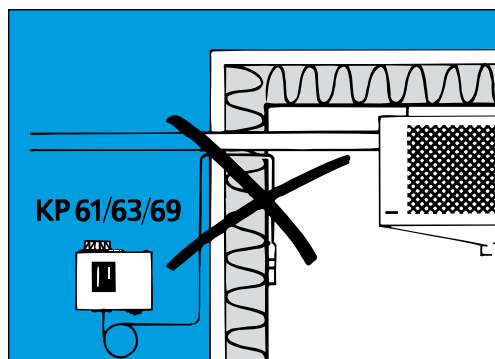

Aj0\_0015

