

Contents

	Page
Installation	21
Placing of surplus capillary tube	22
Setting	22
Low-pressure control.....	22
High-pressure control.....	22
Example with four compressors in parallel (R404A)	23
Setting LP for outdoor location	23
Indicative evaporating pressures (p _e) for different types of systems	23
Test of contact function	24
The correct pressure control for your system.....	25

Installation

Mount the KP pressure control on a bracket or on a completely flat surface.

The pressure control can also be mounted on the compressor itself.

In unfavourable conditions, an angle bracket could amplify vibration in the mounting plane. Therefore, always use a wall bracket where strong vibration occurs.

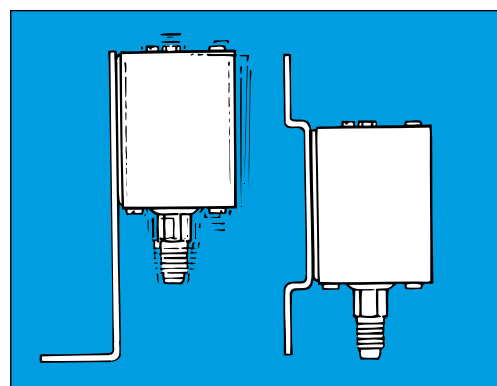

A10_0001

If the risk of water droplets or water spray is present, the accompanying top plate should be used. The plate increases the grade of enclosure to IP 44 and is suitable for all KP pressure controls. To obtain IP 44, the holes in the backplate of the control must be covered by mounting on either an angle bracket (060-105666) or a wall plate (060-105566).

The top plate is supplied with all units incorporating automatic reset. It can also be used on units with manual reset, but in that case must be purchased separately (code no.: for single unit, 060-109766; for dual unit, 060-109866).

If the unit is to be used in dirty conditions or where it might be exposed to heavy spray - from above or from the side - it should be fitted with a protective cap. The cap can be used together with either an angle bracket or a wall bracket.

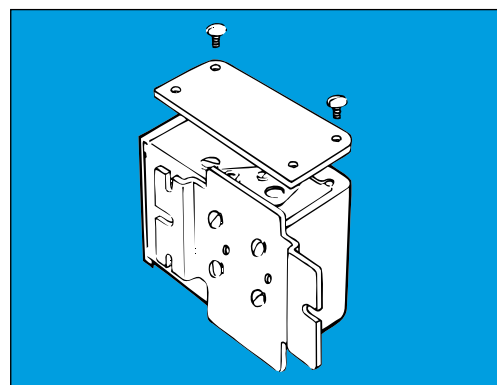

A10_0007

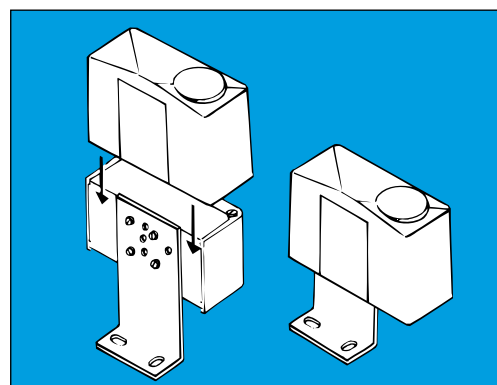

A10_0008

If the unit risk being exposed to heavy water influence a better grade of enclosure can be achieved when mounting the product in a special IP 55 enclosure.

The IP 55 enclosure is available for both single unit (060-033066) and dual unit (060-035066).



Ak0_0020

Installation (cont.)

The pressure connection of the control must always be fitted to the pipe in such a way that liquid cannot collect in the bellows. This risk is present especially when:

- the unit is located in a low ambient condition, e.g. in an air current,
- the connection is made on the underside of the pipe.

Such liquid could damage the high-pressure control.

Consequently, compressor pulsation would not be damped and might give rise to contact chatter.

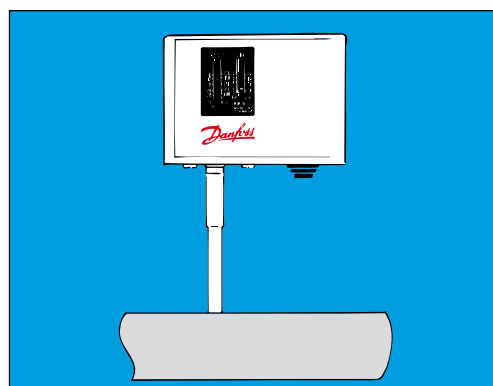

A10_0009

Placing of surplus capillary tube

Surplus capillary tube can fracture if vibration occurs and might lead to complete loss of system charge. It is therefore very important that the following rules are observed:

- When mounting direct on compressor: Secure the capillary tube so that the compressor/control installation vibrates as a whole. Surplus capillary tube must be coiled and bound.

Note:

According to EN rules it is not allowed to use capillary tube for connecting safety pressure controls. In such case a 1/4 inch tube is prescribed.

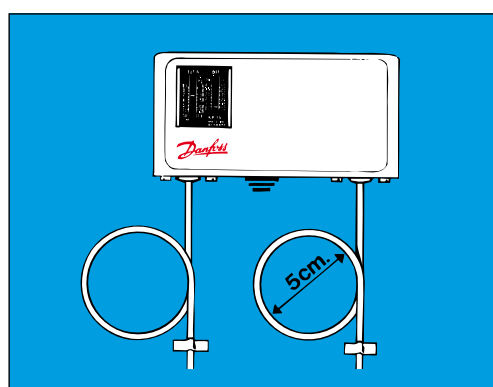

A10_0010

- Other types of mounting: Coil surplus capillary tube into a loose loop. Secure the length of capillary tube between compressor and loop to the compressor. Secure the length of capillary tube between loop and pressure control to the base on which the pressure control is mounted.

In case of very strong vibrations, Danfoss steel capillary tubes with flare connection are recommended:

- Code no. 0.5 m = 060-016666
- Code no. 1.0 m = 060-016766
- Code no. 1.5 m = 060-016866

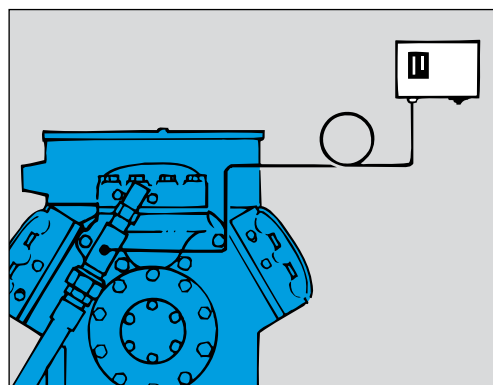

A10_0011

Setting

KP pressure controls can be preset using a compressed air cylinder. Ensure that the change-over contacts are correctly connected for the required function.

Low-pressure control

Set the start pressure (CUT IN) on the range scale (A). Then set the differential on the differential scale (B).
 Stop pressure = CUT IN minus DIFF.

High-pressure control

Set the stop pressure (CUTOUT) on the range scale (A). Then set the differential on the differential scale (B).
 Start pressure = CUT OUT minus DIFF.

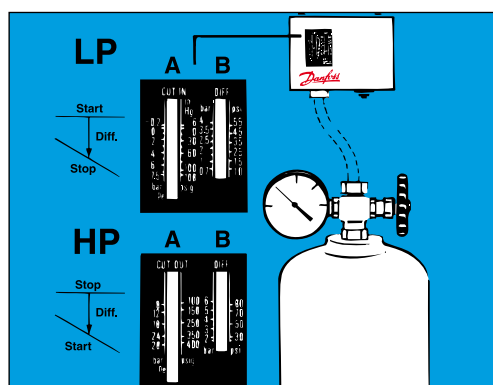

A10_0012

Remember: The scales are indicative only.

Fitter notes
Pressure controls

Example with four compressors in parallel (R404A)

Medium: ice cream at -25°C ,
 $t_0 \approx -37^{\circ}\text{C}$,
 $p_0 \approx -0.5 \text{ bar}$,
 Δp suction line corresponding to 0.1 bar.

Each pressure control (e.g. KP 2) must be set individually in accordance with the following table.

Compressor	CUT OUT	CUT IN
1	-0.05 bar	0.35 bar
2	0.1 bar	0.5 bar
3	0.2 bar	0.6 bar
4	0.35 bar	0.75 bar

The pressure control must be mounted in such a way that liquid cannot collect in the bellows.

Setting LP for outdoor location

If the compressor, condenser and receiver are situated outdoors, KP low pressure must be set to a "CUT IN" setting lower than the lowest occurring pressure (temperature around compressor) during winter operation. In this case, after longer standstill periods the pressure in the receiver determines the suction pressure.

Example:

Lowest occurring temperature around the compressor -20°C means, for R404A, a pressure of 1 bar. CUT IN must be set at -24°C (corresponding to 1.6 bar).

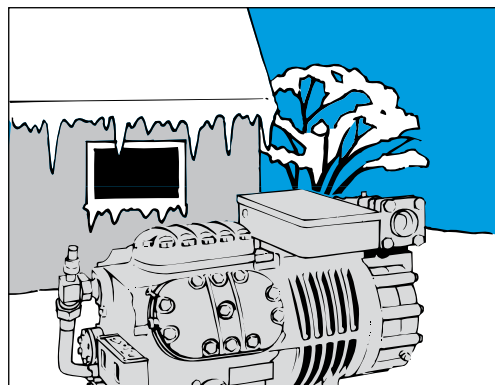

A10_0013

Indicative evaporating pressures (p_e) for different types of systems

Room temp. (t_r)	System type	Difference between t_e and t_{media} (air)	Evaporating pressure (p_e)	RH [%]	Setting of KP2/KP1 (cut in - cut out) D = Operating press. cont. S = Safety press. cont.
$+0.5^{\circ}/+2^{\circ}\text{C}$	Fan-cooled meat cold room	10K	1.0 - 1.1 bar (R134a)	85	0.9 - 2.1 bar (D)
$+0.5^{\circ}/+2^{\circ}\text{C}$	Meat cold room with natural air circulation	12K	0.8 - 0.9 bar (R134a)	85	0.7 - 2.1 bar (D)
$-1^{\circ}/0^{\circ}\text{C}$	Refrigeration meat counter (open)	14K	0.6 bar (R134a)	85	0.5 - 1.8 bar (D)
$+2^{\circ}/+6^{\circ}\text{C}$	Milk cold room	14K	1.0 bar (R134a)	85	0.7 - 2.1 bar (D)
$0^{\circ}/+2^{\circ}\text{C}$	Fruit cold room Vegetable chiller	6K	1.3 - 1.5 bar (R134a)	90	1.2 - 2.1 bar (D)
-24°C	Freezer	10K	1.6 bar (R404A)	90	0.7 - 2.2 bar (S)
-30°C	Ventilated deep freeze room	10K	1 bar (R404A)	90	0.3 - 2.7 bar (S)
-26°C	Ice cream freezer	10K	1.4 bar (R404A)	90	0.5 - 2.0 bar (S)

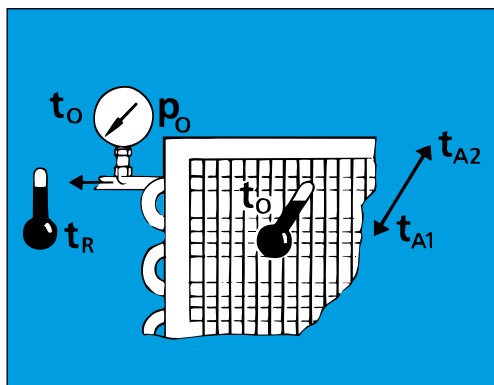

A10_0015

Test of contact function

When the electrical leads are connected and the system is under normal operating pressure, the contact function can be tested manually.

Depending on the bellows pressure and setting, the test device must be pressed up or down.

Any reset mechanism becomes inoperative during the test.

On single units:
Use the test device at top left.

On dual units:
Use the test device on the left for low-pressure testing and the one at bottom right for high-pressure testing.

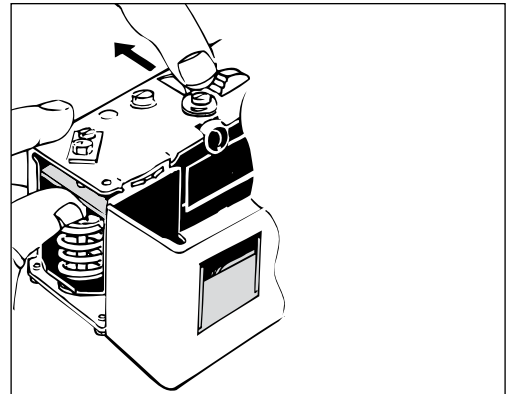

A10_0018



Warning!
The contact function on a KP Pressure Control must never be tested by activating the device at top right. If this warning is ignored, the control may go out of adjustment. In the worst case function can be impaired.

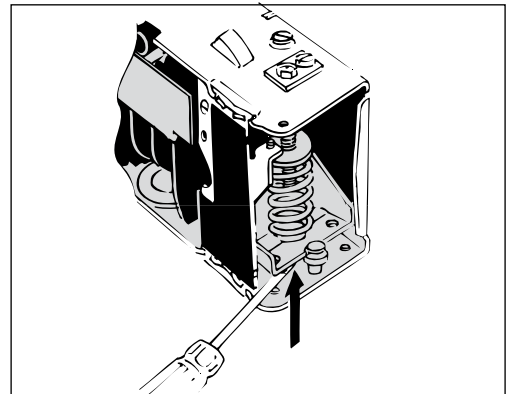

A10_0019

On the KP 15 dual pressure control with optional automatic or manual reset on low-pressure and high-pressure side, automatic reset must be set when servicing is being carried out. The pressure control can then automatically restart. Remember, the original reset function must be set after servicing.

The pressure control can be protected against being set on automatic reset: Simply remove the washer controlling the reset function! If the unit is to be protected against tampering, the washer can be sealed with red lacquer.

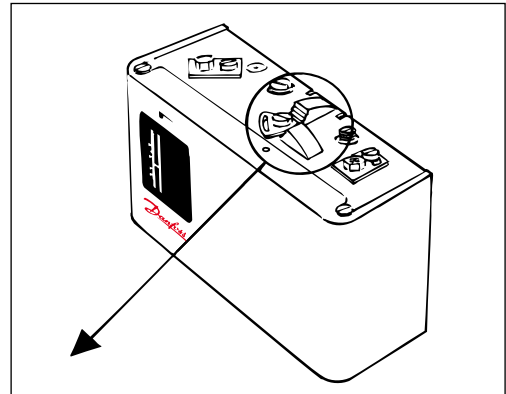

A10_0020

Low pressure	Manual reset *)	Automatic reset	Automatic reset	Manual reset
High pressure	Manual reset *)	Manual reset	Automatic reset	Automatic reset

*) Factory setting

A10_0021

The correct pressure control for your system

KP with solder connections can be used instead of flare connections on hermetic systems.

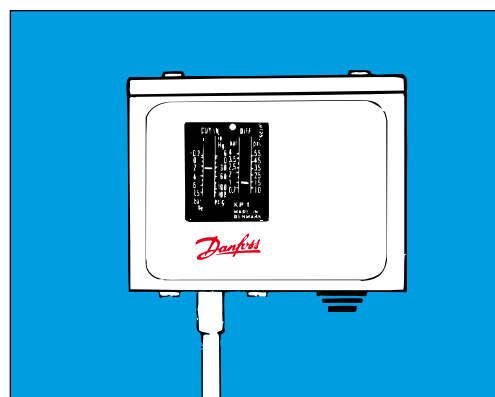

A10_0006

In ammonia plant where KP pressure controls are used, they must be type KP-A. A connector with M10 × 0.75 – 1/4- 18 NPT (code no. 060- 014166).

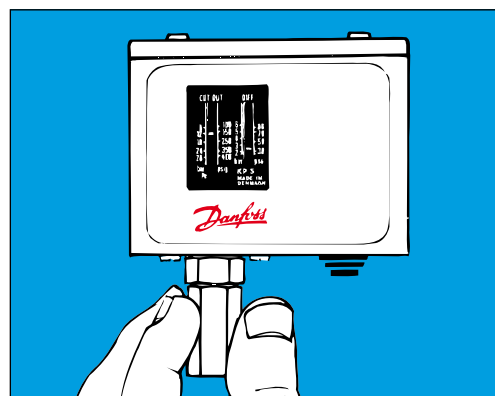

A10_0002

For refrigerating systems containing a large quantity of charge medium and where extra safety is desired/demanded (Fail-safe): Use KP 7/17 with double bellows. The system will stop if one of the bellows ruptures - without loss of charge.

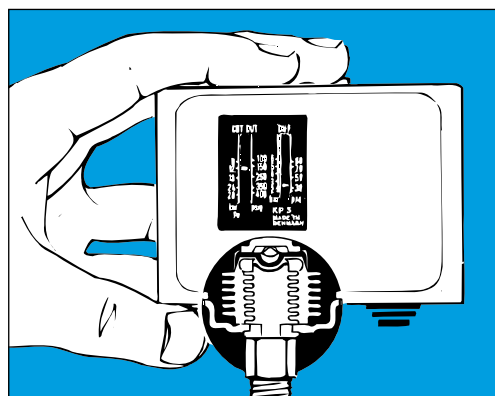

A10_0003

For systems operating with low pressure on the evaporator side, and where the pressure control must regulate (not just monitor): Use KP 2 with a small differential.

An example where pressure control and thermostat are in series:

KP 61 regulates the temperature via compressor stop/start.

KP 2 stops the compressor when suction pressure becomes too low.

KP 61:
 CUT IN = 5°C (2.6 bar)
 CUT OUT = 1°C (2.2 bar)

KP 2 low pressure:
 CUT IN = 2.3 bar
 CUT OUT = 1.8 bar

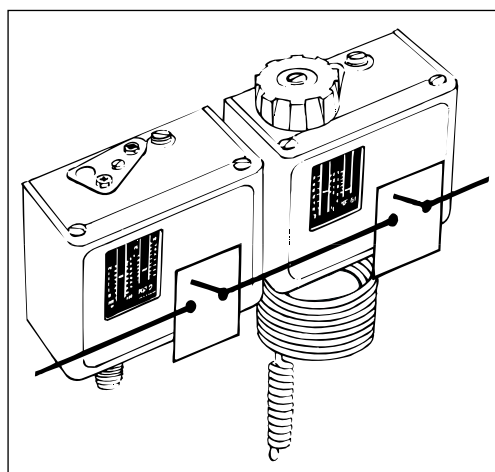

A10_0004

The correct pressure control for your system (cont.)

For systems where KP is activated occasionally (alarm) and for systems where KP is the signal source for PLC, etc.: Use KP with gold contacts; these give good contact at low voltages.

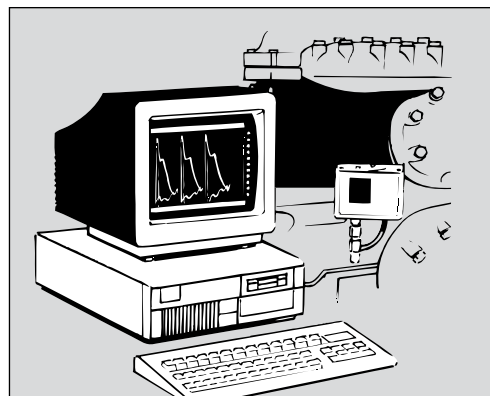

A10_0005